

# QT Universal Clamp



The QT Universal Clamps are used in conjunction with Gripple Universal Brackets or Low Profile Brackets for quick and easy support of all types of pipework within mechanical and plumbing services.

## FEATURES / BENEFITS

- Up to ten times faster than traditional methods
- For pipe sizes 15 mm Copper (OD15) to 4" (OD114) pipework
- Replaces more than 12 different pipe ring sizes
- Simplifies 'take-off' process
- Easy site storage, reduces waste
- Quarter turn fixing - tool free attachment and adjustment
- Retractable sleeve, pre-fitted to wire rope to prevent galvanic corrosion
- Available with Kooltherm / Armaflex pipe collars for insulated pipe
- Supplied in kits with Gripple Universal Brackets or Low Profile Brackets
- Provides insulation against vibration (Noise reduction > 16 db)



## INSTALLATION

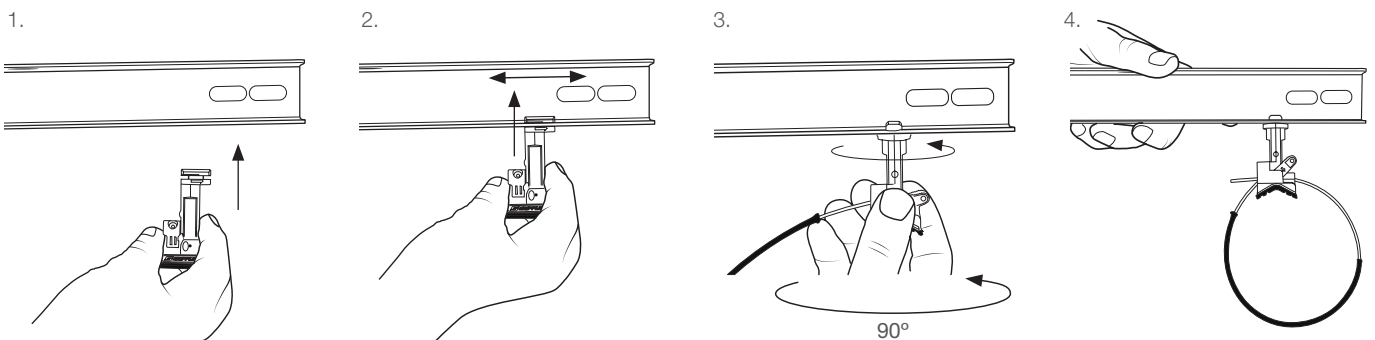

\*Initial installation may require the use of a tool

## SPECIFICATION

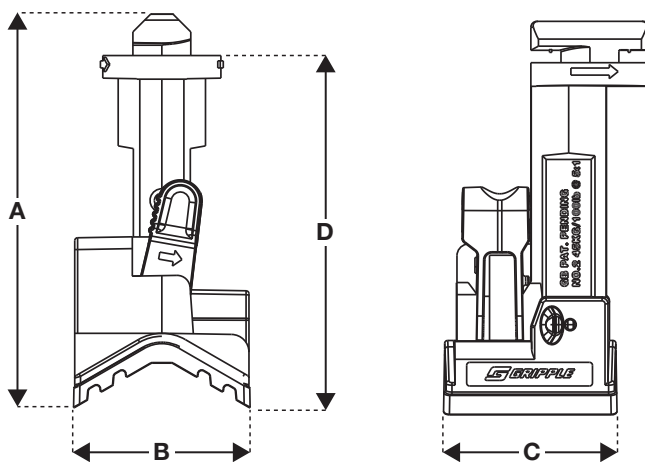

Dimension	Size (mm)
A	68.5
B	30
C	29.5
D	52

## AVAILABLE BRACKETS

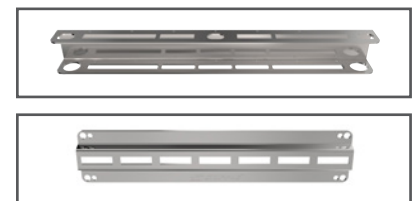

Brackets are available in multiple sizes. For more information please contact us or visit [www.gripple.com](http://www.gripple.com)

## SUBMITTAL INFORMATION

### Load Rating:

75 kg @ 3:1 safety factor

### Material:

**Housing** - Type ZA2 Zinc

**Wedge** - Sintered steel hardened to min. 56 Rockwell C

**Spring** - Stainless Steel (Type 302)

**Pad** - EPDM 4015 Shore A

### Approvals:

Lloyds certified

PI-QTUNICLAMP-ENG

[www.gripple.com](http://www.gripple.com)

Gripple's policy is one of continuous development and innovation. We therefore reserve the right to alter specifications, etc. without notice.



Gripple Ltd | The Old West Gun Works | Savile Street East | Sheffield S4 7UQ  
Tel 0800 018 4264 Fax 0114 275 1155 email [info@gripple.com](mailto:info@gripple.com)