

Fastcats Hanger

A multi-purpose wire rope hanger, ideal for the suspension of a variety of building services.

- Featuring a push-fit design, clear wire entry indicators, and a sliding release button, making it simple to use
- Safe working load of up to 70kg
- Compatible with 1.5mm, 2mm and 2.5mm diameter wire rope
- Laser marked with 6 digit works number



Installation

1.

Insert the wire rope

2.

Loop around the service and feed back through the opposite channel. Ensure at least 100mm of tail wire exits the hanger.

3.

The loop is now secure. Support the load and slide one of the buttons to release the wire and make adjustments.

Specifications

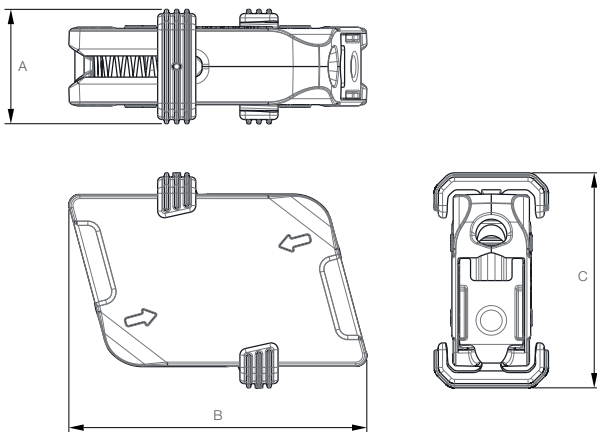

Material

- Housing** - Zinc Alloy (ZL2)
- Buttons** - Acetal (Copolymer)
- Rollers** - Carbon Steel
- End Caps** - Polypropylene
- Springs** - Stainless Steel

Compatibility

- Wire Diameter** - 1.5 mm, 2 mm & 2.5 mm
- Wire Construction** - 7 x 7
- Wire Nominal Tensile Strength** - 1960 MPa

*Pre-Galvanised Class B Wire Rope Manufactured to BS EN 12385

Standard End Fixings



For more options on available end fixings please contact us or visit gripple.net.au

Dimensions (mm)		
A	B	C
14	36	26

Safe Working Load All with a 3:1 safety factor	
Wire Diameter (mm)	Safe Working Load * (kg)
1.5	35
2.0	60
2.5	70

* safe working loads are based on vertical load installations only.